

CCEZ

Heavy Duty Accumulating Conveyor (Zero Pressure Accumulating Type)

The Model CCEZ is a horizontal plastic belt conveyor designed for accumulating 12 & 24 packs of canned beverages where high speeds and large through-puts are required.

- EZLogic® Accumulation System (Retro-Reflective)
- High Speed
- Adjustable MS-Type Floor Supports Available



Conveyor shown with optional floor supports



U.S. Patent Numbers
5,862,907 • 7,243,781 • 7,591,366
Other Patents Pending.



HYTROL CONVEYOR COMPANY, INC.

NOTE: Bed sections available in the following:

- Drive Bed – 8'
- Tail Bed – 2'
- Intermediate Bed Lengths Must be Multiples of Zone Lengths

HOW IT WORKS

The conveyor is made up of 24 in. long accumulation zones. The product is conveyed on a low friction plastic belt. The belt is held against the bottom of the product by means of a pair of air actuators. When accumulation begins, Hytrol's EZLogic® Zone Controllers sense product presence, which causes the air actuators to deflate. This allows the plastic belt to lower and sets the product on a pair of UHMW wear bars, where the product slides to a stop. This sequence will continue until the conveyor is loaded. When the discharge zone is signaled to move forward, all zones behind will move forward in sequence.

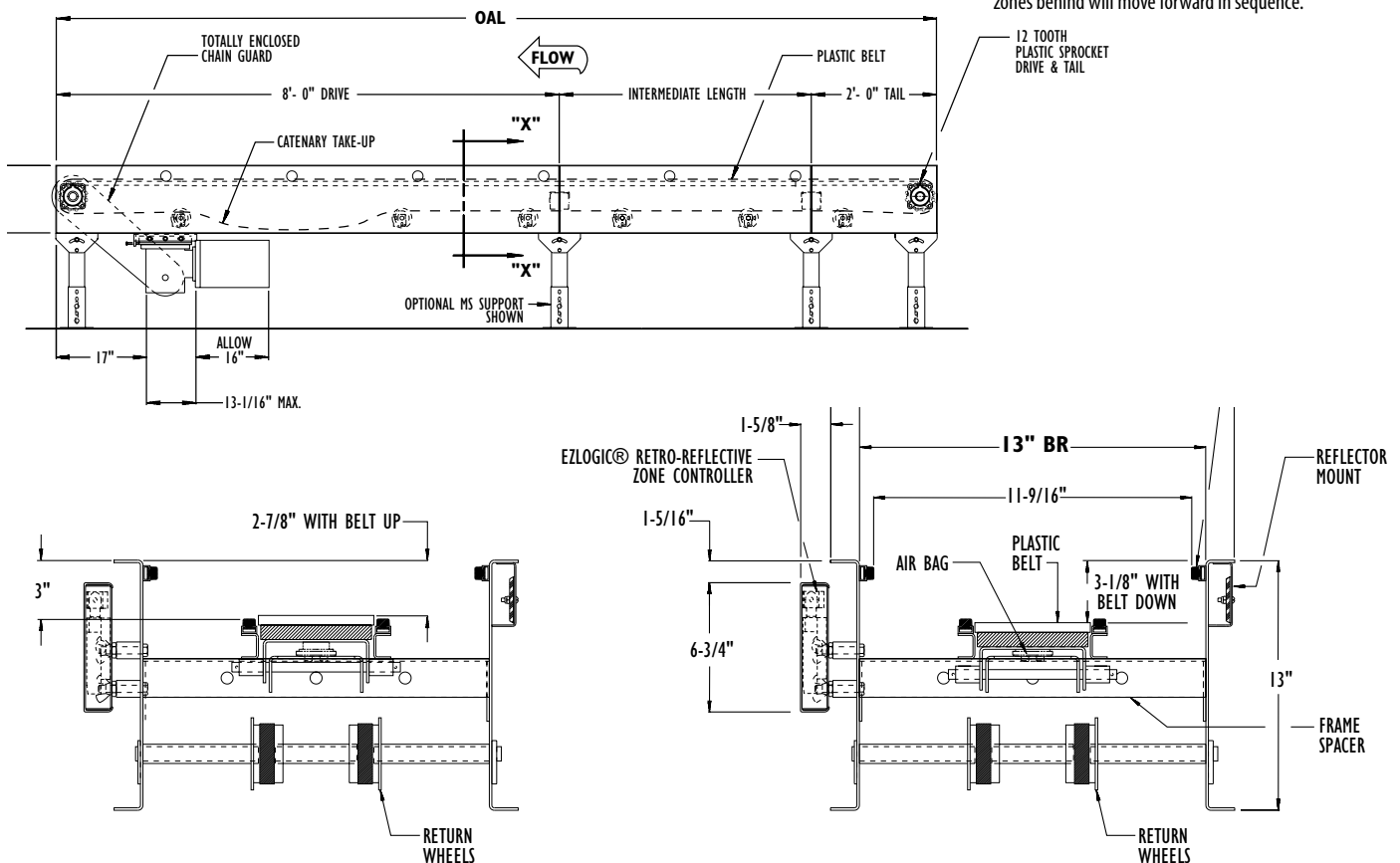

SECTION X-X



• STANDARD SPECIFICATIONS

- BELT**—6 in. wide x ½ in. thick low friction plastic belt.
- FRAME**—13 in. deep x 1 ½ in. flange x 12 ga. powder painted steel frame.
DRIVE—Mounted underneath at discharge end.
- DRIVE & TAIL SPROCKETS**—12 tooth plastic split sprocket keyed to 1 7/8 in. dia. steel shaft.
- TAKE-UP**—Catenary provided at discharge end.
- BEARINGS**—Sealed, pre-lubricated, regreaseable, self-aligning, ball bearings on drive and tail shaft.
- ACCUMULATION ZONES**—24 in. long, air controlled. **Note:** 51 or more zones will require additional power supply and isolation cable and power supply T cable.
- EZLogic® ZONE CONTROLLERS**—Located in each zone (Retro-Reflective). NEMA 1, 2, IP 62. UL Approved.
- IOP**—Provides 27VDC, 100 watt power for EZLogic® accumulation system - contains slots for 4 input/output boards. Operates up to 50 zones (25 each side of IOP). Requires 120VAC or 230VAC single phase input.

- AIR REQUIREMENTS**—Recommended working pressure 25 P.S.I. Free air consumption at 25 P.S.I.—.0026 cu. ft. per zone actuation.
- FILTER REGULATOR**—Supplied for main air supply line. (½ in. NPT port).
- MOTOR**—1 HP—230/460V—3 PH. 60 Hz. Energy Efficient C-Face with AC Variable Speed Controller.
- SPEED REDUCTION**—Sealed worm gear C-Face speed reducer. no.60 roller chain to drive shaft.
- BELT SPEED**—Variable 20 - 200 fpm.
- CAPACITY**—See load capacity chart.
- FLOOR SUPPORTS**—Now supplied as optional equipment.

NOTE: Standard CCEZ is designed to convey cartons 4 cans wide. Use optional 4 ½ in. belt width when conveying cartons 3 cans wide.

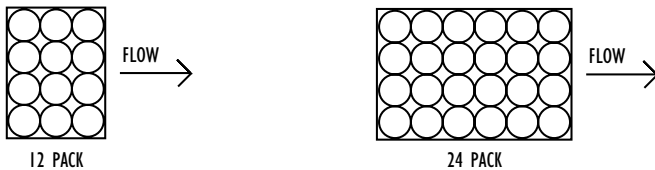

Length	TOTAL LOAD (LBS) @ 200 FPM (Horizontal)				
	34	1	1 ½	2	3
20'	360	500	800	1040	1600
30'	330	480	750	1020	1560
40'	300	440	725	1000	1520
50'	N/A	400	700	940	1500
60'	N/A	360	660	925	1470
70'	N/A	N/A	630	910	1440
80'	N/A	N/A	600	880	1400
90'	N/A	N/A	N/A	840	1350
100'	N/A	N/A	N/A	800	1300

EZLOGIC® ACCUMULATION SYSTEM

Hytrol's EZLogic®, or "Electronic Zero-pressure Logic" Accumulation System, combines the sensing accuracy of photo-electronics with discrete electronic logic control without the use of a PLC or pneumatic logic components. The EZLogic® Accumulation System provides many features including:

Zero-Pressure Accumulation of Product

Zone Stop - Always used at the discharge end of the conveyor line to begin accumulation.

Selectable Modes of Operation

Singulation Mode - Product separates while traveling down the conveyor and when it is released from the conveyor - Zone Off Delay Timer may be used to prevent products from separating while traveling down the conveyor.

Enhanced Slug Mode w/ Jam Protection - Product does not separate when traveling down the conveyor or when it is released from the conveyor. This allows higher product throughput at any given conveyor speed. Product will not separate on the conveyor even when accumulation has been activated at the discharge end.

Cascaded Slug Release - Rather than releasing all zones simultaneously, this function introduces a momentary delay in the release of each zone, from discharge upstream.

Dynamic Zone Allocation - Automatically adjusts the conveyor's zone length to accommodate the length of the product being conveyed. Improves conveyor efficiency and system flexibility.

• OPTIONAL EQUIPMENT

FLOOR SUPPORTS—MS Type floor supports are available with a wide range of adjustment. Specify top of belt or roller elevation. One support required at every bed joint and ends of conveyor. Holes in feet for lagging to floor. Knee braces recommended above MS-6 support.

CONVEYING SPEED—Other constant and variable speeds available. **Note:** Capacity affected with speed change.

SIDE MOUNTED END DRIVE—Motor reducer unit mounted to side of conveyor at discharge end. Minimum elevation to top of belt 14 in.

O-RING DRIVE CHAIN—With sealed in lubricant (Recommended for applications that do not permit regular lubrication).

4 ½ in. Belt Width—For conveying cartons 3 cans wide.

POLY-TIER SUPPORTS—36 in. to 120 in. support heights in 6 in. increments. Knee braces supplied.

CEILING HANGERS—½ in. dia. x 8 ft. long unplated fully threaded rods. Other lengths and galvanized rods available.

EZLogic® - See EZLogic® Components Page.