

C

Cleated Incline Belt Conveyor

The Model C handles bags, boxes, cartons and parts. It may be set at any angle from horizontal to 45° for various uses, including floor-to-floor conveying and the transportation of materials from building to truck or box car.

- 4 Belt Widths
- Reversible
- Cleated Roughtop Belt
- Gravity Conveyor Brackets
- Pop-out Roller
- Undertrussed Bed
- Adjustable MS-Type Floor Supports Available



Conveyor shown with optional floor supports

SIZE TO ORDER Overall Length "A"	Bed Length "L"	"H" @ 40° Infeed @ 30° Discharge @ 30°	"B" @ 40°	14" Belt		18" Belt		24" Belt		30" Belt	
				20" Bed		24" Bed		30" Bed		36" Bed	
				Motor HP	Weight (Lbs.)	Motor HP	Weight (Lbs.)	Motor HP	Weight (Lbs.)	Motor HP	Weight (Lbs.)
7'-5"	6'	—	—	¾	385	¾	585	1 ½	770	1 ½	955
9'-5"	8'	—	—	¾	415	¾	640	1 ½	845	1 ½	1050
11'-5"	10'	—	—	¾	435	1 ½	670	1 ½	880	1 ½	1145
13'-5"	12'	8'-6"	11'-0"	¾	450	1 ½	695	1 ½	910	1 ½	1240
15'-5"	14'	9'-9"	12'-6"	¾	500	1 ½	750	1 ½	985	1 ½	1335
17'-5"	16'	11'-0"	13'-0"	¾	545	1 ½	805	1 ½	1060	1 ½	1430
19'-5"	18'	12'-3"	14'-7"	¾	585	1 ½	860	1 ½	1135	1 ½	1525
21'-5"	20'	13'-6"	16'-1"	1 ½	615	1 ½	915	1 ½	1210	1 ½	1620
23'-5"	22'	14'-9"	17'-7"	1 ½	655	1 ½	970	1 ½	1285	1 ½	1715
25'-5"	24'	16'-0"	19'-2"	1 ½	700	1 ½	1025	1 ½	1360	1 ½	1810
27'-5"	26'	17'-3"	20'-8"	1 ½	730	1 ½	1080	1 ½	1430	1 ½	1905
29'-5"	28'	18'-6"	22'-2"	1 ½	755	1 ½	1135	1 ½	1505	1 ½	2000
31'-5"	30'	19'-6"	23'-9"	1 ½	790	1 ½	1190	1 ½	1580	1 ½	2095
33'-5"	32'	21'-0"	25'-3"	1 ½	825	1 ½	1245	1 ½	1650	1 ½	2190
35'-5"	34'	22'-3"	26'-10"	1 ½	860	1 ½	1310	1 ½	1720	1 ½	2285
37'-5"	36'	23'-6"	28'-4"	1 ½	895	1 ½	1375	1 ½	1790	1 ½	2380
39'-5"	38'	24'-9"	29'-10"	1 ½	930	1 ½	1430	1 ½	1860	1 ½	2475
41'-5"	40'	26'-0"	31'-5"	1 ½	965	1 ½	1495	1 ½	1930	1 ½	2570
43'-5"	42'	27'-3"	32'-11"	1 ½	1000	1 ½	1560	1 ½	2000	1 ½	2665
45'-5"	44'	26'-6"	34'-5"	1 ½	1035	1 ½	1625	1 ½	2070	1 ½	2760

All weights in catalog are conveyor weights only. Accessories, crating, etc., are not included.

GUARD RAILS—Adjustment Chart

Belt Width	Bed Width	"S" Cleat Spacing	"G"	"W"
14"	20"	6"	17 ½" to 26 ½"	22 ½" to 31 ½"
18"	24"	10"	21 ½" to 30 ½"	26 ½" to 35 ½"
24"	30"	10"	27 ½" to 36 ½"	32 ½" to 41 ½"
30"	36"	14"	33 ½" to 42 ½"	38 ½" to 47 ½"

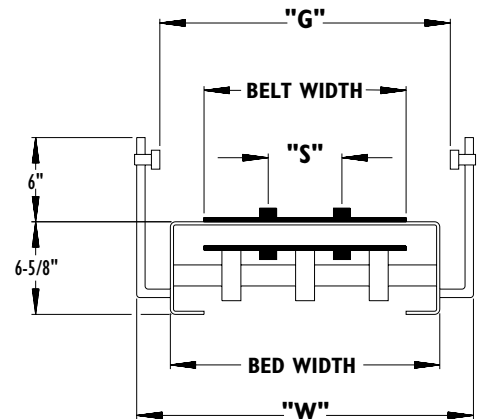
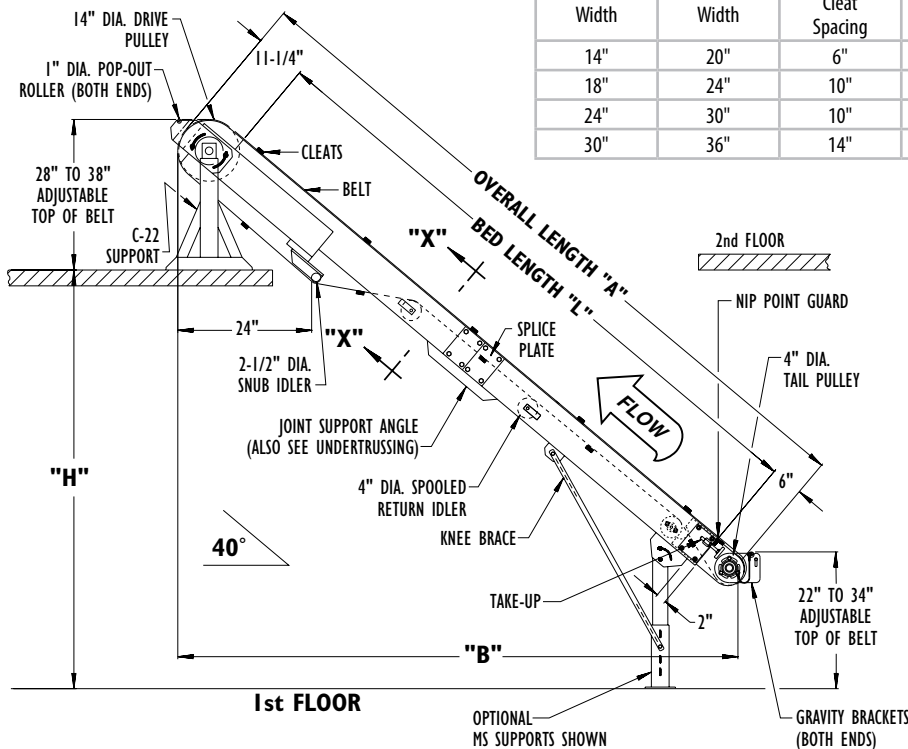

SECTION X-X
SHOWN WITH OPTIONAL ADJUSTABLE CHANNEL GUARD RAILS

• STANDARD SPECIFICATIONS

END DRIVE—Located on discharge end of conveyor.

BELT—Black Trackmate 120 Roughtop with PVC cover. Clipper lacing.

CLEATS—Two 1 ½ in. dia. x 1 in. high hardwood cleats, fastened to belt by ⅝ in. elevator bolts spaced every 60 in. Can be supplied less cleats. Specify.

BED—6 ⅝ in. deep x 12 ga. powder painted, formed steel slider bed. Reinforced with ¾ in. pipe which forms sockets for guard rails. Standard 6 ft., 8 ft., and 10 ft. long sections bolt together with splice plates.

UNDERTRUSSED BED—Undertrussing provided on beds from 20 ft. through 40 ft. long. Others supported by either MS type floor supports or ceiling hangers. Unsupported bed joints are reinforced by joint support angles.

INCLINE—Adjustable from horizontal to 45°.

DRIVE PULLEY—14 in. dia. with 1 in. dia. removable shaft for 20 in. wide bed; 1 ¼ in. dia. removable shaft for 24 and 30 in. wide beds. Crowned and fully lagged.

TAIL PULLEY—4 in. dia. with 1 in. dia. shaft at bearing, machine crowned.

SNUB IDLER—Adjustable 2 ½ in. dia. pre-lubricated ball bearings.

RETURN IDLER—Adjustable 4 in. dia. spooled idler to provide clearance for cleats. Pre-lubricated ball bearings.

TAKE-UP—Take-ups at tail pulley. Provides 4 in. of belt take-up.

GRAVITY BRACKETS—Adjustable bars with 1 in. dia. pop-out transfer roller to attach wheel or 1 ⅝ in. dia. roller conveyor.

BEARINGS—Sealed, pre-lubricated, self-aligning, ball bearings at tail pulley. Re-lube roller bearings on drive pulley.

MOTOR—Energy efficient motor with brake. See chart.

BELT SPEED—Constant 65 FPM.

CAPACITY—See Load Capacity Chart.

FLOOR SUPPORTS—Now supplied as optional equipment.



SHOWN WITH OPTIONAL LOWER POWERED FEEDER AND SUPPORTS

LIVE LOAD CAPACITY-40° INCLINE @ 65 FPM				
HP	BELT WIDTHS TO	LENGTHS UP TO		
		20'	30'	46'
DISTRIBUTED LOAD (LBS.)				
¾	14"	250	240	230
	18"	245	235	220
	24"	240	225	205
	30"	235	220	190
1 ½	14"	520	515	500
	18"	515	505	490
	24"	510	495	475
	30"	505	490	460

• OPTIONAL EQUIPMENT

FLOOR SUPPORTS—MS Type floor supports are available with a wide range of adjustment. Specify top of belt or roller elevation. One support required at every bed joint and ends of conveyor. Holes in feet for lagging to floor. Knee braces recommended above MS-3 support.

BELT—Brown Polymate Roughtop w/Nitrile cover.

BELT SPEED—Other constant speeds available, contact factory.

*NOTE: Capacity affected with speed change.

GUARD RAILS—Adjustable Universal Channel Guard Rail.

LOWER POWERED FEEDER—Chain type driven from pulley of inclined conveyor. NOTE: Conveyor tail pulley is used for belt take-up. When belt tension is adjusted, feeder will have to be moved along with the take-up. NOTE: Capacity affected with this option.

PULLEYS—6 in. dia. tail pulley with 1 ⅜ in. dia. shaft at bearing.

FLOOR SUPPORTS—Infeed end (MS type) heights other than standard available, specify elevation. Discharge end (C-22) higher than standard to 48 in., specify elevation.

CEILING HANGERS—⅝ in. dia. x 8 ft. long unplated rods fully threaded. Other lengths and galvanized rods available.

REMOTE SWITCH CONTROL—Rod running length of conveyor to operate reverse drum switch from both ends. Switch regularly furnished on left side, looking up with drive at top. Specify if required on other side.

MOTORS—1 ½ HP maximum.

CONVEYING SPEED—Speeds other than 65 FPM will require gear box change (contact factory).

ELECTRICAL CONTROLS—One direction manual start switch, reverse drum switch, non-reversing and reversible magnetic starters, push button stations. AC variable frequency drive.