

Portable Folding Booster Belt Conveyor

One lever control adjusts angle without effort. Desired angle automatically locked by powered screw.

- 6 Lengths
- 14" Wide Roughtop Belt
- Reversible
- Bed Section Folds
- Adjustable Infeed Height



ADJUSTMENT CHART FOR 10' TO 16' LONG UNITS													
SIZE TO ORDER	Overall Length "A"	Base Length "B"	Angle Of Incline	"C" @ 14 1/2"			Angle of Incline	"C" @ 32"			"D"	"F"	Weight (Lbs.)
				"H"	"E"	"L"		"H"	"E"	"L"			
10'	10'-7"	4'-7"	8° Min.	2'-5"	5'-0"	10'-5"	3°	2'-8"	5'-8"	10'-7"	44"	6'-6" Max.	560
			25°	5'-3"	4'-2"	9'-7"	25°	6'-11"	4'-8"	9'-7"			
			30°	6'-0"	3'-9"	9'-2"	30°	7'-8"	4'-3"	9'-2"			
			45° Max.	8'-0"	2'-2"	7'-7"	36°	-	-	-			
12'	12'-7"	5'-7"	8° Min.	2'-9"	6'-0"	12'-5"	3°	2'-8"	6'-8"	12'-7"	68"	6'-6" Max.	600
			25°	6'-1"	5'-0"	11'-5"	25°	7'-9"	5'-6"	11'-5"			
			30°	7'-0"	4'-6"	10'-11"	30°	8'-8"	5'-0"	10'-11"			
			45° Max.	9'-5"	2'-7"	9'-0"	36°	-	-	-			
14'	14'-7"	6'-7"	8° Min.	3'-0"	7'-0"	14'-5"	3°	2'-8"	7'-8"	14'-7"	80"	7'-6" Max.	650
			25°	7'-0"	5'-10"	13'-3"	25°	8'-7"	6'-4"	13'-3"			
			30°	8'-0"	5'-3"	12'-8"	30°	9'-8"	5'-9"	12'-8"			
			45° Max.	10'-10"	3'-0"	10'-5"	36°	-	-	-			
16'	16'-7"	7'-7"	8° Min.	3'-4"	8'-0"	16'-5"	3°	2'-8"	8'-8"	16'-7"	92"	8'-6" Max.	700
			25°	7'-10"	6'-8"	15'-1"	25°	9'-5"	7'-2"	15'-1"			
			30°	9'-0"	6'-0"	14'-5"	30°	10'-8"	6'-6"	14'-5"			
			45° Max.	12'-3"	3'-5"	11'-10"	36°	-	-	-			

ADJUSTMENT CHART FOR 20' TO 22' LONG UNITS													
SIZE TO ORDER	Overall Length "A"	Base Length "B"	Angle Of Incline	"C" @ 14 1/2"			Angle of Incline	"C" @ 36"			"D"	"F"	Weight (Lbs.)
				"H"	"E"	"L"		"H"	"E"	"L"			
20'	20'-7"	9'-6"	10° Min.	4'-7"	10'-0"	20'-3"	3°	3'-0"	11'-0"	20'-7"	68"	14'-7" Max.	940
			25°	9'-6"	8'-5"	18'-8"	25°	11'-5"	9'-0"	18'-7"			
			30°	11'-0"	7'-8"	17'-11"	30°	12'-11"	8'-3"	17'-10"			
			45° Max.	15'-1"	4'-5"	14'-8"	36°	-	-	-			
22'	22'-7"	9'-6"	10° Min.	4'-11"	12'-0"	22'-3"	3°	3'-0"	13'-0"	22'-7"	92"	14'-7" Max.	990
			25°	10'-4"	10'-3"	20'-6"	25°	12'-3"	10'-10"	20'-5"			
			30°	12'-0"	9'-4"	19'-7"	30°	13'-11"	10'-0"	19'-7"			
			45° Max.	16'-6"	5'-10"	16'-1"	36°	-	-	-			

All Weights in catalog are conveyor weights only. Accessories, crating, etc., are not included

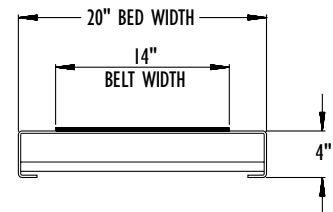

SECTION X-X

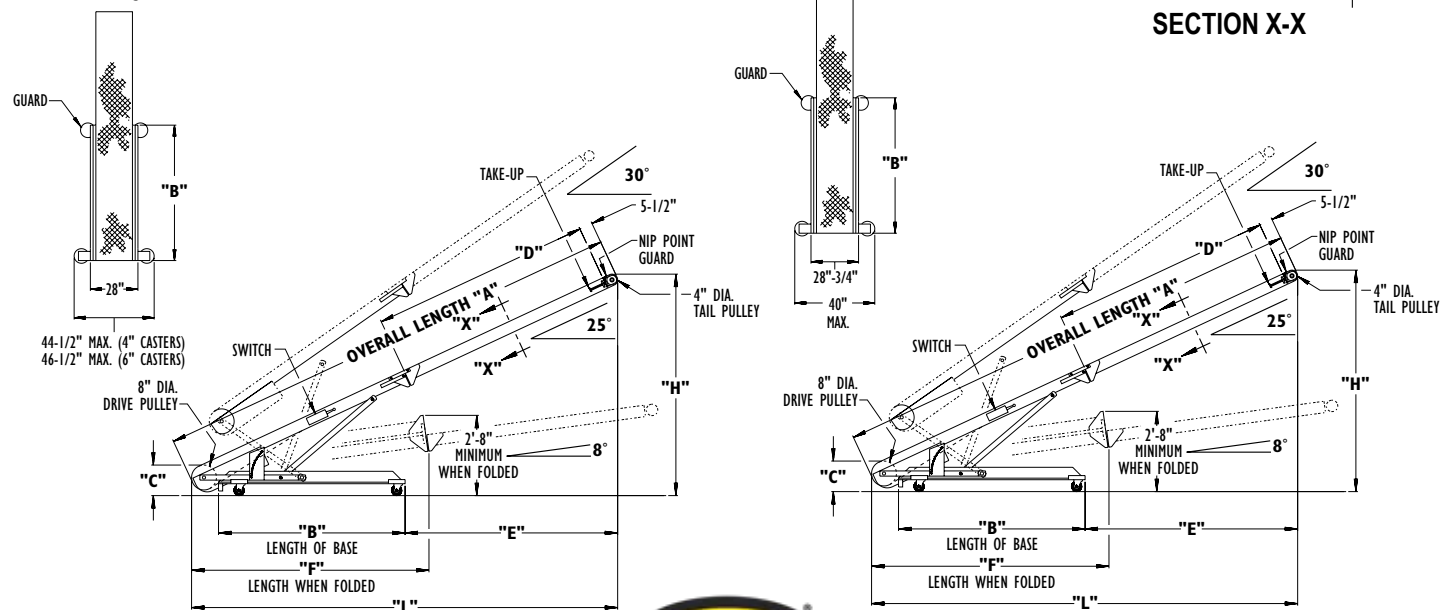

• STANDARD SPECIFICATIONS

BELT—14 in. wide Black Trackmate 120 Roughtop with PVC cover. Clipper lacing.

BED—4 in. deep x 20 in. wide x 12 ga. formed steel slider bed, powder painted. Bed is hinged for storage purposes (see drawing).

HINGES—To fold bed to shorter length for storage. Screw adjustment insures alignment of bed. Exclusive link (breathing feature) prevents damage of belt.

INCLINE—Adjustable with conveyor motor powered screw raising device (see chart for angles). Safety nut prevents rapid release of bed in case of overloading.

INFEED HEIGHT—Adjustable with variable position support.

BASE—Welded steel base (see drawing for dimensions).

CASTERS—4 in. dia. steel swivel casters on 10 ft. to 16 ft. lengths and 6 in. dia. casters on 20 ft. and 22 ft. long bed. Corner guards.

DRIVE PULLEY—8 in. dia. with 1 in. dia. removable shaft. Machine crowned and fully lagged.

TAIL PULLEY—4 in. dia. with 1 in. dia. shaft at bearings, machine crowned.

SNUB IDLER—Adjustable 2 ½ in. dia. pre-lubricated ball bearings.

RETURN IDLER—Adjustable 1.9 in. dia. pre-lubricated ball bearings.

TAKE-UP—Take-ups provided at tail pulley. Provides 4 in. of belt take-up.

BEARINGS—Sealed, pre-lubricated, self-aligning, cast-iron ball bearings on tail pulley. Re-lube roller bearings on drive pulley.

SPEED REDUCTION—Sealed worm gear speed reducer driven by V-belt. No. 50 roller chain to drive pulley.

MOTOR—1 HP (10 ft. to 22 ft.)—115/230V—1 Ph. 60 Hz. Totally Enclosed. Wired for 115 volt.

ELECTRICAL CONTROLS—Reversing drum switch with 20 ft. power cord and plug.

BELT SPEED—Constant 65 FPM.

CAPACITY—300 lbs. total distributed load, 150 lbs. unit load at 65 FPM.

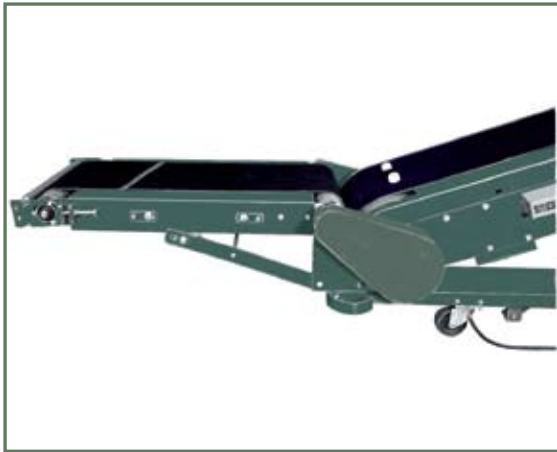

LOWER POWERED FEEDER



HINGED BED FOLDS FOR EASY STORAGE

• OPTIONAL EQUIPMENT

RUBBER CASTERS—6 in. dia. rubber swivel casters in place of steel casters.

FLOOR LOCKS—Two foot operated toggle floor locks mounted on one side of conveyor base to prevent unit from moving when in operation.

GRAVITY CONVEYOR BRACKET—Adjustable bar for connecting wheel or roller gravity conveyor.

LOWER GRAVITY FEEDER—2 ft. long x 18 in. wide (1 ½ SW-18-36) includes adjustable tubular support and gravity conveyor bracket.

UPPER GRAVITY FEEDER—2 ft. long x 18 in. wide (3 SW-18-18) includes adjustable tubular support and gravity conveyor bracket.

LOWER POWERED FEEDER—Chain type driven from drive pulley. 43 in. long belt feeder section includes adjustable tubular support and gravity conveyor bracket.

GUARD RAILS—Channel type, adjustable vertically (specify fixed horizontal width). Not foldable with guard rails.

TROUGHING ATTACHMENT—Flat steel supports under belt form trough for handling loose material. Hopper available. Not foldable with troughing attachment.

REMOTE SWITCH CONTROL—Rod running length of conveyor to operate reverse drum switch from both ends. Switch regularly furnished on right side (when standing at drive pulley and looking up toward tail pulley).

MOTORS—2 HP 230/1/60.