

# HYTROL CONVEYOR COMPANY, INC.

## Model **190-LR** Horizontal Power Conveyor (Live Roller)

The Model 190-LR is a belt driven live roller conveyor designed to transport medium to heavy cartons. Applications vary from manufacturing to distribution operations.

- 12 Bed Widths
- Center Drive
- Reversible
- Pop-Out Tread Roller
- Adjustable MS-Type Floor Supports Available



Conveyor shown with optional floor supports

SIZE TO ORDER Overall Length "A"	Between Rail Width	13"	15"	17"	19"	21"	23"	25"	27"	31"	33"	37"	39"
	Drive Belt Width	6"	6"	8"	8"	8"	12"	12"	12"	16"	16"	16"	16"
	Overall Frame Width	16"	18"	20"	22"	24"	26"	28"	30"	34"	36"	40"	42"
10'	WEIGHTS (Lbs.) Weights Based on 3" Roller Centers	520	545	570	595	640	680	705	730	770	790	880	920
15'		685	710	745	775	835	895	930	965	1030	1060	1170	1225
20'		820	845	885	925	1000	1075	1120	1160	1230	1260	1415	1490
25'		990	1015	1065	1110	1205	1295	1345	1395	1485	1525	1700	1785
30'		1120	1145	1200	1255	1365	1475	1535	1590	1675	1715	1935	2045
40'		1410	1435	1510	1580	1725	1865	1940	2010	2120	2170	2460	2600
50'		1705	1730	1820	1910	2085	2255	2345	2435	2565	2625	2915	3055
60'		8000	2025	2130	2235	2440	2645	2750	2855	3005	3080	3500	3710
70'		2295	2320	2440	2560	2800	3035	3160	3280	3450	3535	4025	4270
80'		2590	2615	2750	2885	3160	3430	3570	3705	3895	3990	4540	4810
90'		2885	2910	3060	3210	3515	3820	3975	4130	4345	4450	5070	5380
100'		3175	3200	3370	3540	3880	4220	4385	4550	4790	4910	5600	5940

For 4", 6" & 8" Centers Deduct Weights Listed Below

Roller Centers	BR Width	5' Long Bed Sections												10' Long Bed Sections											
		13"	15"	17"	19"	21"	23"	25"	27"	31"	33"	37"	39"	13"	15"	17"	19"	21"	23"	25"	27"	31"	33"	37"	39"
4"	Weight Deduction	12	30	33	35	40	45	48	50	57	60	67	70	24	57	62	67	77	86	91	95	108	114	127	133
6"		24	42	46	49	56	63	67	70	80	84	94	98	48	84	91	98	112	126	133	140	159	168	187	196
8"		31	54	59	63	72	81	86	90	102	108	120	126	60	102	111	119	136	157	164	170	193	204	227	238

All weights in catalog are conveyor weights only. Accessories, crating, etc., are not included.

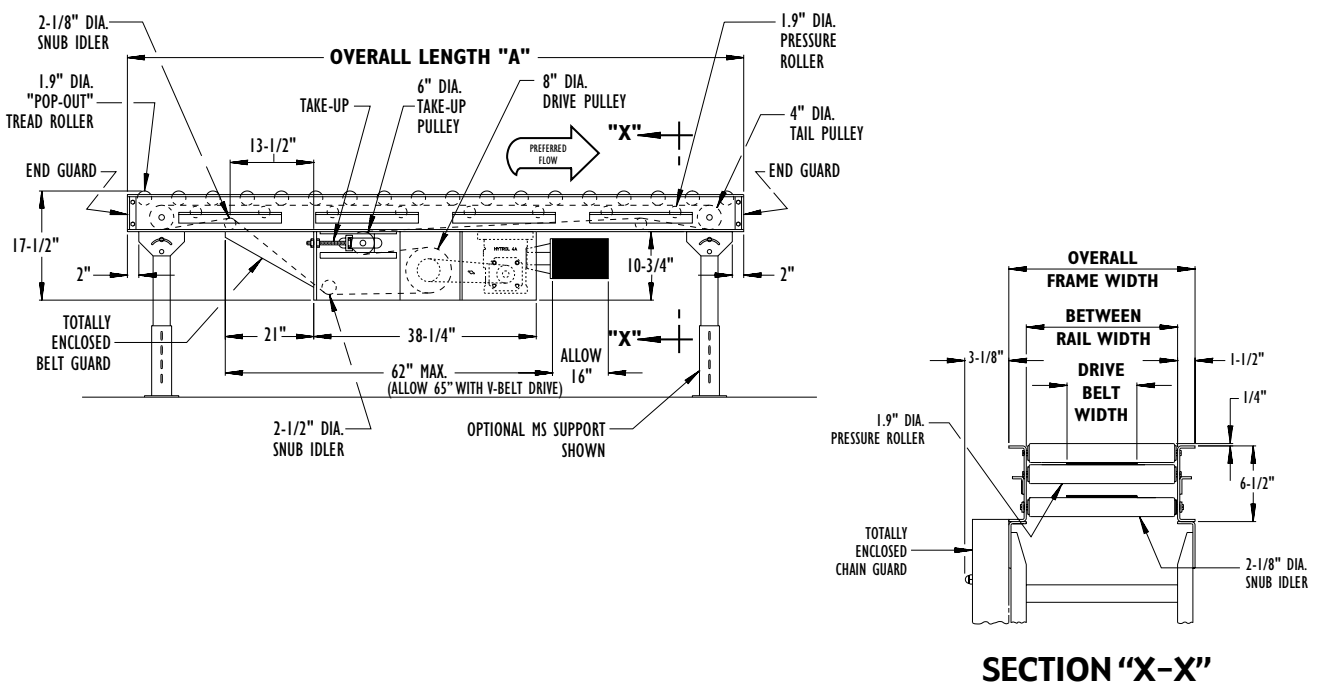

**LIVE ROLLER**



# • Standard Specifications

Model **190-LR**

**BELT**—Ultimate 140 SD—Nitrile.

**BED**—Roller bed with 1.9 in. dia. roller x 16 ga. galvanized tube spaced every 3 in. and 1.9 in. dia. pressure roller x 16 ga. galvanized tube spaced every 6 in. Mounted in 6-1/2 in. x 12 ga. powder painted formed steel channel frame bolted together with butt couplings.

**CROSS BRACING**—Rods with turnbuckles are fastened to underside of bed to provide proper alignment of bed rollers and insure correct product tracking. Supplied on every other section, 30 ft. lengths and over.

**CENTER DRIVE**—Can be placed in any section of conveyor length.

**DRIVE PULLEY**—8 in. dia. with 1-7/16 in. dia. shaft at bearings, fully lagged.

**TAIL PULLEY**—4 in. dia. with 1 in. dia. shaft at bearings, machine crowned.

**TAKE-UP PULLEY**—6 in. dia. with 1-3/16 in. dia. shaft crowned.

**SNUB IDLER**—Adjustable 2-1/8 in. dia. pre-lubricated ball bearings.

**RETURN IDLER**—Adjustable 1.9 in. dia. pre-lubricated ball bearings.

**TAKE-UP**—Take-ups in center drive provide 16 in. of belt take-up.

**BEARINGS**—Sealed, pre-lubricated, self-aligning, ball bearings on drive, tail, and take-up pulleys. Pre-lubricated ball bearings in tread and pressure rollers.

**SPEED REDUCTION**—Sealed worm gear C-Face speed reducer. No. 50 roller chain to drive pulley.

**MOTOR**—1/2 HP—208/230/460/575V—3 Ph.—60 Hz. Totally Enclosed C-Face.

**BELT SPEED**—Constant 65 FPM.

**CAPACITY**—Maximum load per linear foot of conveyor 200 lbs. NOT TO EXCEED capacity in chart.

**FLOOR SUPPORTS**—Now supplied as optional equipment.

LOAD CAPACITY CHART @ 65 FPM						
HP	OVERALL FRAME WIDTH 16" TO 22"		OVERALL FRAME WIDTH 24" TO 30"		OVERALL FRAME WIDTH 34" TO 42"	
	TOTAL LOAD (LBS.)		TOTAL LOAD (LBS.)		TOTAL LOAD (LBS.)	
	UP TO 50'	UP TO 100'	UP TO 50'	UP TO 100'	UP TO 50'	UP TO 100'
1/2	1100	200	600	-	-	-
1	3300	2400	2800	1600	2200	-
2	7000	6000	6400	5200	5800	3300

## • Optional Equipment

**FLOOR SUPPORTS**—MS Type floor supports are available with a wide range of adjustment. Specify top of belt or roller elevation. One support required at every bed joint and ends of conveyor. Holes in feet for lagging to floor. Knee braces recommended above MS-6 support.

**CONVEYING SPEED**—Other constant and variable speeds available. V-belt drive supplied on speeds under 17 FPM. NOTE: Capacity affected with speed change.

**SIDE MOUNTED CENTER DRIVE**—Motor reducer unit mounted to side of conveyor. Minimum low elevation 16 in.

**LOW ELEVATION SIDE MOUNTED END DRIVE**—Minimum elevation 12-1/4 in. (low elevation underside take-up required).

**V-BELT DRIVE**—V-belt supplied between motor and reducer. Allow 65 in.

**O-RING DRIVE CHAIN**—With sealed in lubricant (Recommended for applications that do not permit regular lubrication).

**PACKAGE STOPS**—Hand operated blade or roller, air operated pin or roller, angle and raised roller end stops.

**PLOWS**—Manual and pneumatic (see Accessory section)

**GUARD RAILS**—Adjustable Universal Channel Guard Rail, fixed channel or type A angle, elevated to allow for pop-out tread rollers. Fixed channel overlapping, one direction. Fixed channel nonoverlapping, reversing with channels raised with spacers to allow for pop-out tread rollers.

**ROLLER CENTERS**—Tread rollers spaced every 4 in., 6 in., or 8 in. Not available on all bed lengths.

**POLY-TIER SUPPORTS**—36 in. to 120 in. support heights in 6 in. increments. Knee braces supplied.

**CEILING HANGERS**—5/8 in. dia. x 8 ft. long unplated rods fully threaded. Other lengths and galvanized rods available.

**MOTORS**—Energy efficient, single phase, brakemotor, other characteristics. 2 HP maximum.

**ELECTRICAL CONTROLS**—Non-reversing or magnetic starters and push-button stations. AC variable frequency drive.

