

# 190-ACZ

## Horizontal Power Conveyor (Accumulating Type)

The Model ACZ accumulates cartons, boxes, etc. Basic design eliminates complicated adjustments and allows a minimum of 2% Back Pressure.

- 12 Bed Widths
- 2% Minimum Back Pressure
- Finger Tip Snub Roller Adjustment, Both Sides
- Reversible
- Center Drive
- Adjustable MS-Type Floor Supports Available



Conveyor shown with optional floor supports



SIZE TO ORDER Overall Length "A"	Between Rail Width	13"	15"	17"	19"	21"	23"	25"	27"	31"	33"	37"	39"
	Drive Belt Width	6"						8"					
	Overall Frame Width	16"	18"	20"	22"	24"	26"	28"	30"	34"	36"	40"	42"
10'	WEIGHTS (Lbs.) Weights Based on 3" Roller Centers	385	416	448	479	509	551	581	612	679	720	771	803
15'		521	552	596	637	679	733	774	816	908	950	1033	1077
20'		657	688	744	797	849	915	967	1020	1137	1190	1295	1351
25'		793	824	898	956	1019	1097	1160	1224	1366	1430	1557	1625
30'		929	960	1040	1115	1189	1279	1353	1428	1595	1670	1819	1899
35'		1065	1096	1188	1274	1359	1461	1546	1632	1824	1910	2081	2173
40'		1201	1232	1336	1433	1529	1643	1739	1836	2053	2150	2343	2447
45'		1337	1368	1484	1592	1699	1825	1932	2040	2282	2390	2605	2721
50'		1473	1504	1632	1751	1869	2007	2125	2244	2511	2630	2867	2995
55'		1609	1640	1780	1910	2039	2189	2318	2448	2740	2870	3129	3269
60'		1745	1776	1928	2069	2209	2371	2511	2652	2969	3010	3391	3543
65'		1886	1917	2076	2228	2379	2553	2704	2856	3198	3350	3653	3817
70'		2017	2048	2224	2387	2549	2735	2897	3060	3427	3590	3915	4091
75'		2153	2184	2372	2546	2719	2917	3090	3264	3656	3830	4177	4365
80'		2289	2320	2520	2705	2889	3099	3283	3468	3885	4070	4439	4639
85'		2425	2456	2668	2864	3059	3281	3476	3672	4114	4310	4701	4913
90'		2561	2592	2816	3023	3229	3463	3669	3876	4343	4550	4963	5187
95'		2697	2728	2964	3182	3399	3645	3862	4080	4572	4790	5225	5461
100'		2833	2864	3112	3341	3569	3827	4055	4284	4801	5030	5487	5735

All weights in catalog are conveyor weights only. Accessories, crating, etc., are not included.

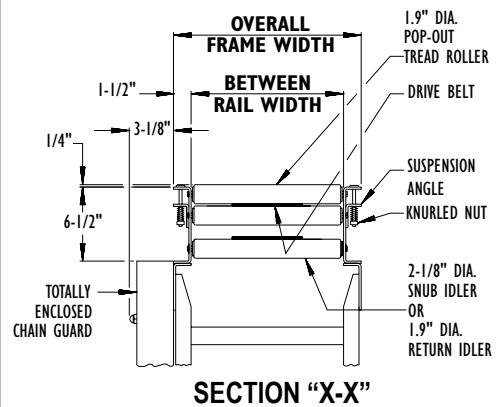
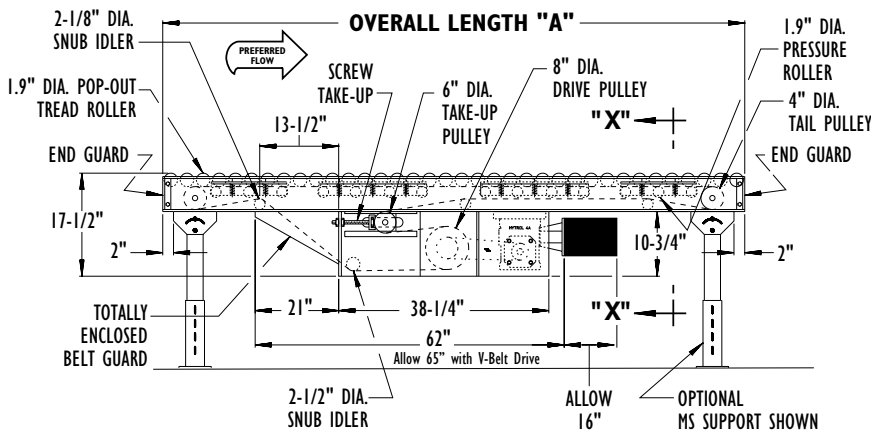

## • STANDARD SPECIFICATIONS

**BELT**—Ultimate 140 BBS—Nitrile.

**BED**—Roller bed with 1.9 in. dia. roller x 16 ga. galvanized tube spaced every 3 in. and 1.9 in. dia. pressure roller x 16 ga. galvanized tube spaced every 6 in. Mounted in 6 ½ in. x 12 ga. powder painted formed steel channel frame bolted together with butt couplings.

**CROSS BRACING**—Rods with turnbuckles are fastened to underside of bed to provide proper alignment of bed rollers and insure correct product tracking. Supplied on every other section 30 ft. bed lengths and over.

**CENTER DRIVE**—Can be placed in any section of conveyor length.

**DRIVE PULLEY**—8 in. dia. with 1 ¾ in. dia. shaft at bearings, fully lagged.

**TAIL PULLEY**—4 in. dia. with 1 in. dia. shaft at bearings, machine crowned.

**SNUB IDLER**—Adjustable 2 ½ in dia. pre-lubricated ball bearings.

**RETURN IDLER**—Adjustable 1.9 in dia. pre-lubricated ball bearings.

**TAKE-UP**—Take-ups in center drive. Provides 16 in. of belt take-up.

**BEARINGS**—Sealed, pre-lubricated, self-aligning, ball bearings on drive, tail, and take-up pulleys. Pre-lubricated ball bearings in tread and pressure rollers.

**SPEED REDUCTION**—Sealed worm C-Face gear reducer. No. 50 roller chain to drive sheave.

**MOTOR**—½ HP—208/230/460/575V—3 PH. 60 Hz. Totally Enclosed C-Face.

**CONVEYING SPEED**—Constant 65 FPM.

**CAPACITY**—Maximum load per linear foot of conveyor 150 lbs. NOT TO EXCEED capacity in chart.

**FLOOR SUPPORTS**—Now supplied as optional equipment.

LOAD CAPACITY CHART @ 65 FPM

HP	OVERALL FRAME WIDTH 16" TO 22"		OVERALL FRAME WIDTH 24" TO 30"		OVERALL FRAME WIDTH 34" TO 42"	
	TOTAL LOAD (LBS.)		TOTAL LOAD (LBS.)		TOTAL LOAD (LBS.)	
	UP TO 50'	UP TO 100'	UP TO 50'	UP TO 100'	UP TO 50'	UP TO 100'
½	1100	200	600	—	—	—
1	3300	2400	2800	1600	2200	—
2	7000	6000	6400	5200	5800	3300

## • OPTIONAL EQUIPMENT

**FLOOR SUPPORTS**—MS Type floor supports are available with a wide range of adjustment. Specify top of belt or roller elevation. One support required at every bed joint and ends of conveyor. Holes in feet for lagging to floor. Knee braces recommended above MS-6 support.

**CONVEYING SPEED**—Other constant and variable speeds from 20 to 90 FPM. V-belt drive supplied under 46 FPM (2 HP) and with variable speeds. **NOTE:** Capacity and accumulation feature affected with speed change.

**SIDE MOUNTED LOW ELEVATION CENTER DRIVE**—Motor reducer unit mounted to side of conveyor. Minimum low elevation 16 in.

**SIDE MOUNTED END DRIVE**—Minimum elevation 12 ¼ in. (underside take-up required).

**V-BELT DRIVE**—V-belt supplied between motor and reducer. Allow 65 in.

**O-RING DRIVE CHAIN**—With sealed in lubricant (Recommended for applications that do not permit regular lubrication).

**PACKAGE STOPS**—Roller or pin type stops available, contact factory.

**GUARD RAILS**—Adjustable Universal Channel Guard Rail, fixed channel, type A angle elevated to allow for pop-out tread rollers. Type B angle not available. (See Accessory section.) **NOTE:** If product comes in contact with guard rails, product flow will be affected. Fixed channel overlapping, one direction. Fixed channel non-overlapping, reversing.

**ROLLER CENTERS**—Tread rollers spaced every 4 in., 6 in., or 8 in. (4 in. or 8 in. centers NOT AVAILABLE in 7 ft. 6 in. bed).

**POLY-TIER SUPPORTS**—36 in. to 120 in. support heights in 6 in. increments. Knee braces supplied.

**CEILING HANGERS**—½ in. dia. x 8 ft. long unplated rods fully threaded. Other lengths and galvanized rods available.

**MOTORS**—Energy efficient, single phase, brakemotor, other characteristics. 2 HP maximum.

**ELECTRICAL CONTROLS**—Non-reversing or reversible magnetic starters and push-button stations. AC variable frequency drive.