

HYTROL CONVEYOR COMPANY, INC.

Models **138-LRC**

Live Roller Curve Conveyor

The Model 138-LRC is a light-duty live roller curve that provides a positive drive for negotiating 90°, 60°, 45°, or 30° turns. It may be self-powered or can be slave driven from 138-ACC, LRS or LRSS conveyors.

- 4 Bed Widths
- Reversible
- Adjustable LS-Type Floor Supports Available



Conveyor shown with optional floor supports



138-LRC

Between Rail Width	Overall Frame Width	"A"	"B"	"C"	"R"	Number of Rollers**				WEIGHTS (Lbs.)			
						90°	60°	45°	30°	90°	60°	45°	30°
10"	12"	3 1/16" MAX.	9 3/4"	9 5/8"	25"					272	262	252	242
13"	15"					30S	38S	34S	30S	278	268	258	248
16"	18"					22T/4S	14T/12S	10T/12S	6T/12S	287	277	267	257
22"	*24"									302	292	282	272

All weights in catalog are conveyor weights only. Accessories, crating, etc., are not included.

*NOTE: 24 in. OAW curve has 1.9 in. dia. tapered & straight rollers mounted in a 6 1/2 in. x 1 in. x 12 ga. painted form steel channel.

*T = TAPERED
S = STRAIGHT

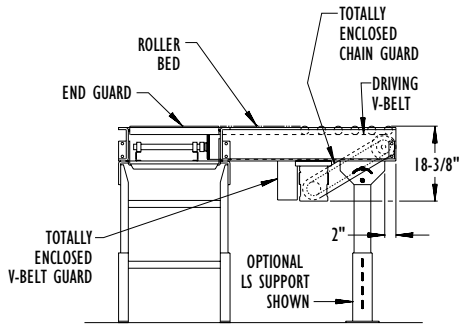

SECTION "X-X"

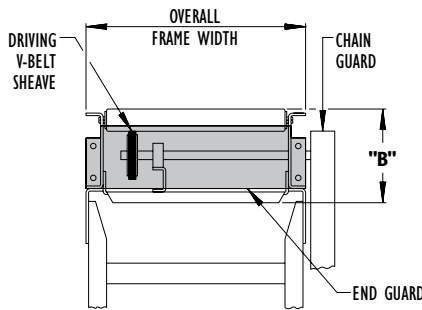

SECTION "Y-Y"

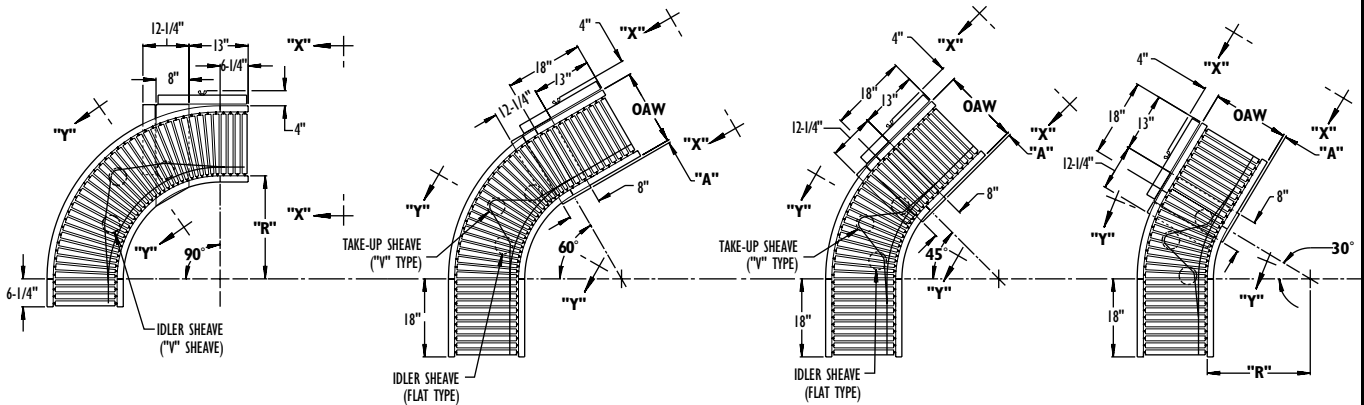
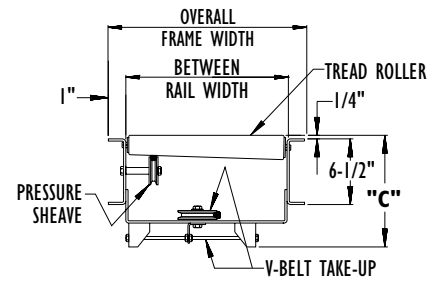

ACCUMULATION - MINIMUM PRESSURE



• Standard Specifications

Model **138-LRC**

BED-(LRC) Roller bed with 1-3/8 in. dia. roller x 18 ga. galvanized tube and 5/16 in. HRS hex shafts (12 in.-18 in. OAW) and 2-1/2 in. dia. tapered to 1-11/16 in. dia. roller x 16 ga. galvanized tube and 1.9 in. dia. straight rollers x 16 ga. galvanized tube 7/16 in. HRS hex shafts (24 in. OAW). Mounted in 6-1/2 in. x 12 ga powder painted formed steel channel frame.

END DRIVE-Mounted underneath bed section on outside radius.

DRIVING BELT-Endless B-section V-Belt, industrial grade.

PRESSURE SHEAVES-2-1/2 in. dia. with 3/8 in. bore.

IDLER SHEAVE-4 in. dia. x 5/8 in. bore V type and/or 5-1/2 in. dia. x 5/8 in. bore flat type.

TAKE-UP-Take-ups provided to maintain proper V-belt tension. Includes 4-3/8 in. dia. x 5/8 in. bore V type take-up sheave.

BEARINGS-Sealed, pre-lubricated, self aligning ball bearings with eccentric lock collar on flange and pillow block bearings. Pre-lubricated ball bearings in tread rollers.

BUTT COUPLINGS-Standard for connecting 138-ACC, 138-LRS, and 138-LRSS.

SPEED REDUCTION-Sealed worm gear reducer, driven by V-belt. No. 50 roller chain to drive sheave.

MOTOR-1/2 HP-208/230/460/575V-3 PH. 60 Hz. Totally Enclosed.

CONVEYING SPEED-Constant 65 FPM.

CAPACITY-150 lbs. total distributed live load.

FLOOR SUPPORTS-Now supplied as optional equipment.

Horsepower required to slave-drive LRC's & LRCT's from ACC's affect the lengths of ACC's due to the capacities of the driving V-belt. The four (4) arrangements shown, illustrate basic slave limitations. Other arrangements are possible.

NOTES

- CURVES MAY BE 30°, 45°, 60°, & 90°
- CURVES ARE NOT ACCUMULATING
- SNUB ROLLER ADJUSTMENT IS ON DRIVE BELT SIDE OF CONVEYOR

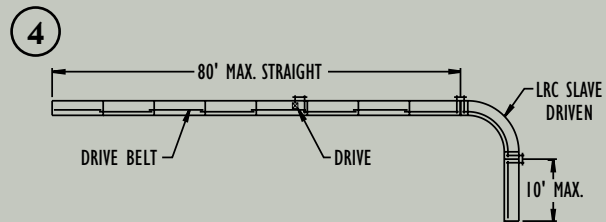
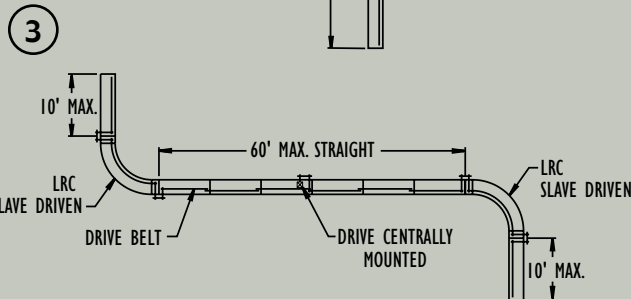
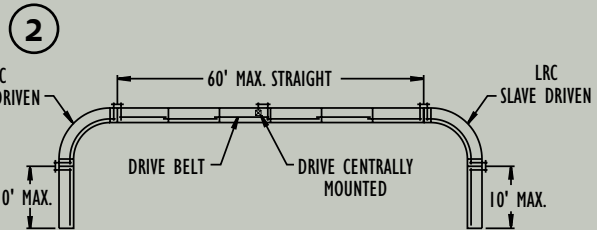
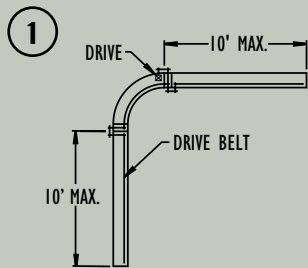

• Optional Equipment

FLOOR SUPPORTS-LS Type floor supports are available with a wide range of adjustment. Specify top of belt or roller elevation. One support required at every bed joint and ends of conveyor. Holes in feet for lagging to floor. Knee braces recommended above LS-6 support.

CONVEYING SPEED-Other constant and variable speeds from 25 to 90 FPM. NOTE: Capacity affected with speed change.

END DRIVE-Mounted on inside radius. Minimum elevation 18-7/8".

SIDE MOUNTED DRIVE-Motor reducer unit mounted to side of conveyor. Specify inside or outside. Minimum elevation 11-1/16 in.

O-RING DRIVE CHAIN-With sealed in lubricant (Recommended for applications that do not permit regular lubrication).

GUARD RAILS-Adjustable Universal Channel Guard Rail, fixed channel, type A or B angle. See Accessory section. NOTE: If product comes in contact with guard rails, product flow will be affected.

POLY-TIER SUPPORTS-36 in. to 120 in. support heights in 6 in. increments. Knee braces supplied.

CEILING HANGERS-5/8 in. dia. x 8 ft. long unplated rods fully threaded. Other lengths and galvanized rods available.

SLAVE DRIVEN-Standard drive may be omitted and curve slave driven from 138-ACC. (Specify by sketch, location of slave connection). Minimum elevation 10-1/2 in.

MOTORS-Energy efficient, single phase, brakemotor, other characteristics. 1 HP maximum.

ELECTRICAL CONTROLS-Non-reversing or reversible magnetic starters and push-button stations. AC variable frequency drive.

