

# ABLR

## Live Roller Conveyor

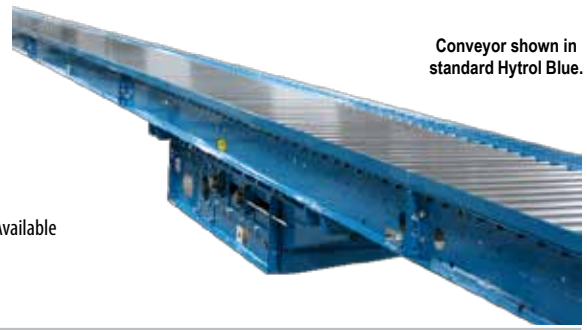

Conveyor shown in standard Hytrol Blue.

The Model ABLR is a horizontal belt driven live roller conveyor, designed to transport medium to heavy cartons. Applications vary from manufacturing to distribution operations.

- 11 Bed Widths
- Center Drive
- Reversible
- Adjustable MS-Type Floor Supports Available

Between Rail Width	15"	17"	19"	21"	23"	25"	27"	31"	33"	37"	39"
Overall Frame Width	18"	20"	22"	24"	26"	28"	30"	34"	36"	40"	42"
10'-0" Base Weight	670	693	716	739	762	785	808	854	877	923	946
Weight Per Foot	31	33	35	37	39	41	43	47	49	53	55

All weights in catalog are conveyor weights only. Accessories, crating, etc., are not included.  
 Total Weight = 10' Base Weight + per foot weight x extra length

HYTROL CONVEYOR COMPANY, INC.

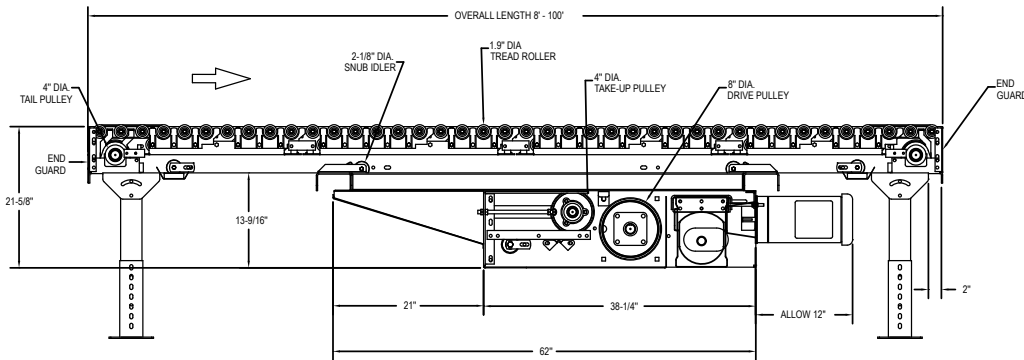

**STANDARD DRIVE**  
 (Located in First Bed Section 8' or Longer, From Infeed End)

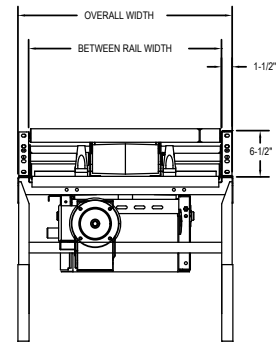

**SECTION "X-X"**

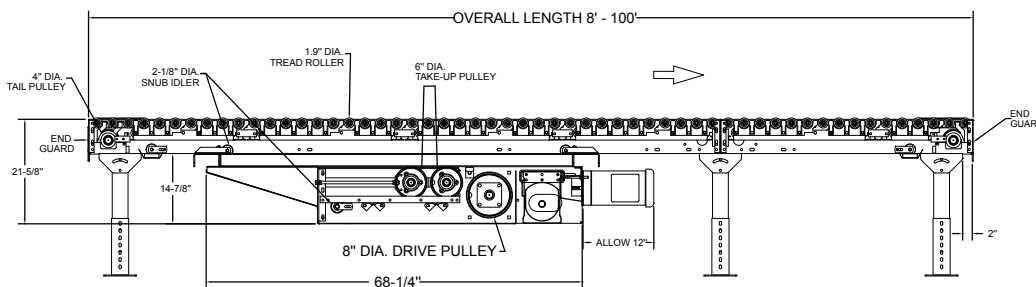

**HIGH PERFORMANCE DRIVE**  
 (Located in First Bed Section 9' or Longer, From Infeed End)



## • STANDARD SPECIFICATIONS

**BELT**—6 in. Black Ultimate 140 SD.

**BED**—Roller bed with 1.9 in. dia. roller x 16 ga. galvanized tube spaced every 3 in. Mounted in 6 ½ in. x 12 ga. powder painted formed steel channel frame bolted together with butt coupling.

**CROSS BRACING**—Rods with turnbuckles are fastened to underside of bed to provide proper alignment of bed rollers and insure tracking. (1) supplied in first 50' of bed section lengths and (1) per 50' of bed section length thereafter. Supplied in approximate center of lengths.

**CENTER DRIVE**—Can be placed in any section of conveyor 7'-6" or longer. Center drive is 18 in. OAW on all widths.

**DRIVE PULLEY**—8 in. dia. with 1 7/8 in. dia. shaft at bearings.

**TAIL PULLEY**—4 in. dia. with 1 7/8 in. dia. shaft at bearings, machine crowned.

**TAKE-UP PULLEY**—6 in. dia. with 1 3/8 in. dia. shaft at bearings, machine crowned.

**SNUB IDLER**—Adjustable 2 ½ in. dia. pre-lubricated ball bearings.

**RETURN IDLER**—Adjustable 1.9 in. dia. pre-lubricated ball bearings.

**TAKE-UP**—Take-ups in center drive. Provides 16 in. of belt take-up.

**BEARINGS**—Sealed, pre-lubricated, self-aligning, ball bearings on drive and tail pulleys. Pre-lubricated ball bearings in tread and pressure rollers.

**SPEED REDUCTION**—Sealed worm gear C-Face speed reducer. No. 50 roller chain to drive shaft.

**MOTOR**—½ HP—208/230/460/575V—3 Ph. 60 Hz. Totally Enclosed C-Face.

**CONVEYING SPEED**—Constant 65 FPM.

**CAPACITY**—Maximum load per linear foot of conveyor 150 lbs. Total load NOT TO EXCEED capacity in charts.

**FLOOR SUPPORTS**—Now supplied as optional equipment.

LOAD CAPACITY CHART @ 65 FPM						
HP	OVERALL FRAME WIDTH 18" TO 22"		OVERALL FRAME WIDTH 24" TO 30"		OVERALL FRAME WIDTH 34" TO 42"	
	TOTAL LOAD (LBS.)		TOTAL LOAD (LBS.)		TOTAL LOAD (LBS.)	
	UP TO 50'	UP TO 100'	UP TO 50'	UP TO 100'	UP TO 50'	UP TO 100'
½	1100	200	600	—	—	—
1	3300	2400	2800	1600	2200	—
2	7000	6000	6400	5200	5800	3300

## • OPTIONAL EQUIPMENT

**FLOOR SUPPORTS**—MS Type floor supports are available with a wide range of adjustment. Specify top of belt or roller elevation. One support required at every bed joint and ends of conveyor. Holes in feet for lagging to floor. Knee braces recommended above MS-6 support.

**CONVEYING SPEED**—Other constant and variable speeds. FPM. V-belt drive supplied under 17 FPM.  
**Note:** Capacity affected with speed change.

**HIGH PERFORMANCE UNDERSIDE CENTER DRIVE**—Required on units over 100 ft long, maximum length 200'-0" (used with 2 HP, 3 HP or 5 HP motor and reducers).

**SIDE MOUNTED LOW ELEVATION CENTER DRIVE**—Motor reducer unit mounted to side of conveyor. Minimum low elevation 16 in. with old style and 18 in. with new style.

**V-BELT DRIVE**—V-Belt supplied between motor and reducer. Allow 65 in.

**O-RING DRIVE CHAIN**—With sealed in lubricant (Recommended for applications that do not permit regular lubrication).

**GUARD RAILS**—Adjustable Universal Channel Guard Rail. See Accessory section. **NOTE:** If product comes into contact with Guard Rails, product flow will be affected. Fixed channel overlapping-one direction.

**PACKAGE STOPS**—Angle and raised roller end stops.

**POLY-TIER SUPPORTS**—36 in. to 120 in. support heights in 6 in. increments. Knee braces required.

**CEILING HANGERS**—5/8 in. dia. x 8 ft. long unplated steel rods fully threaded. Other lengths and galvanized rods available.

**MOTORS**—Energy efficient, single phase, other characteristics. 2 HP maximum.

**ELECTRICAL MOTOR CONTROLS**—Non-reversing magnetic starters and push-button stations. AC variable frequency drive.