

190-LRS

The Model 190-LRS Live Roller Spur is used in diverging or converging applications. It may be self-powered or can be slave driven from 190-ACC, LRC, or LRSS conveyors.

Live Roller Spur Conveyor

- 12 Bed Widths
- Reversible
- Right or Left Hand Units Available
- Adjustable MS-Type Floor Supports Available

Conveyor shown with optional floor supports



HYTROL CONVEYOR COMPANY, INC.

| Between Rail Width | Overall Frame Width | "R" | "A" | | "B" | | "C" | | "D" | | "E" | | Number of Rollers* | | WEIGHTS (Lbs.) | |
|--------------------|---------------------|---------|-----|-----|-----|-----|-----|-----|----------|----------|----------|-----------|--------------------|---------|----------------|-----|
| | | | 45° | 30° | 45° | 30° | 45° | 30° | 45° | 30° | 45° | 30° | 45° | 30° | 45° | 30° |
| 13" | 16" | 24" | 29" | 38" | 27" | 36" | 21" | 30" | 21 7/8" | 38" | 50" | 42 7/2" | 13S/8T | 12S/10T | 195 | 206 |
| 15" | 18" | 32 1/2" | 32" | 41" | 30" | 39" | 36" | 54" | 34 3/32" | 63" | 66 5/8" | 61 19/32" | 18S/10T | 20S/14T | 224 | 245 |
| 17" | 20" | | 35" | 47" | 33" | 45" | | | | | | | | | 233 | 255 |
| 19" | 22" | | 38" | 50" | 36" | 48" | | | | | | | | | 241 | 264 |
| 21" | 24" | | 41" | 53" | 39" | 51" | | | | | | | | | 250 | 270 |
| 23" | 26" | | 44" | 56" | 42" | 54" | | | | | | | | | 262 | 287 |
| 25" | 28" | | 47" | 62" | 45" | 60" | | | | | | | | | 276 | 299 |
| 27" | 30" | 50" | 65" | 48" | 63" | 282 | 311 | | | | | | | | | |
| 31" | 34" | 48" | 56" | 74" | 54" | 72" | 48" | 75" | 48" | 88 3/32" | 86 1/16" | 85 1/2" | 22S/14T | 27S/22T | 322 | 380 |
| 33" | 36" | | 59" | 77" | 57" | 75" | | | | | | | | | 329 | 390 |
| 37" | 40" | | 65" | 86" | 63" | 84" | | | | | | | | | 340 | 406 |
| 39" | 42" | | 68" | 89" | 66" | 87" | | | | | | | | | 351 | 416 |

*T = TAPERED

S = STRAIGHT

All weights in catalog are conveyor weights only. Accessories, crating, etc., are not included.

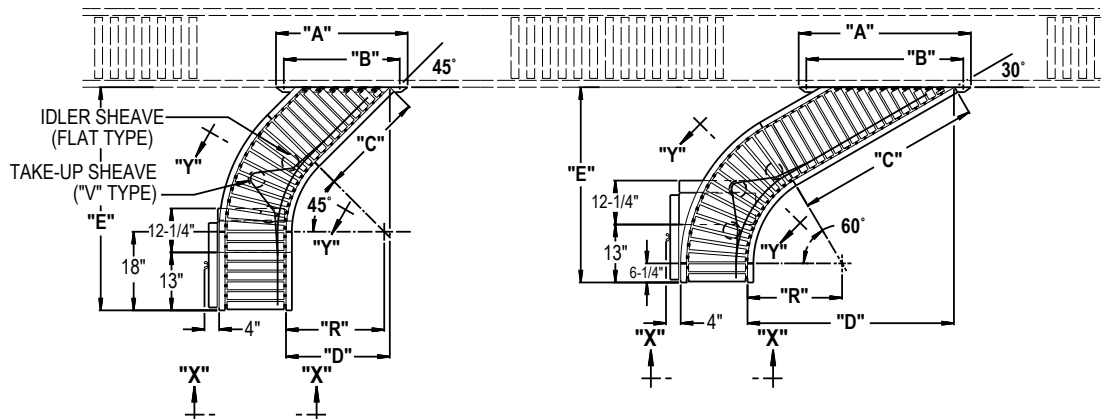
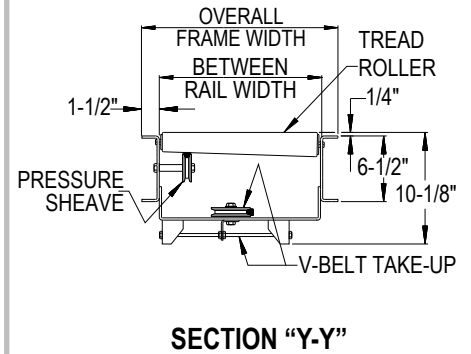
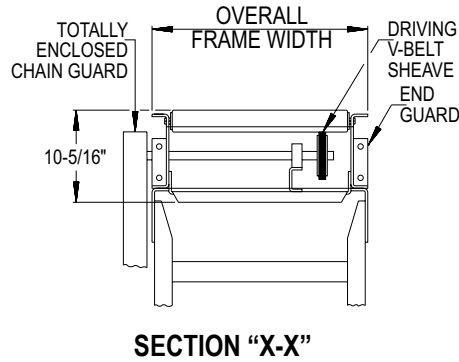
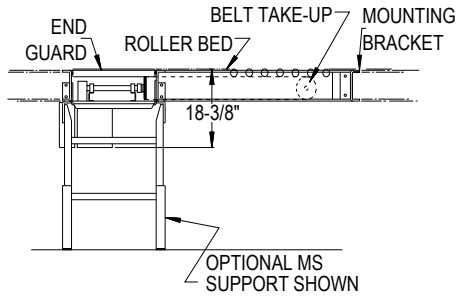

• STANDARD SPECIFICATIONS

BED—Roller bed with 2 1/2 in. dia. tapered to 1 1/4 in. dia. roller x 14 ga. galvanized and 1.9 in. dia. roller x 16 ga. galvanized tube. Mounted in 6 1/2 in. x 12 ga. powder painted formed steel channel frame.

END DRIVE—Mounted underneath bed section on outside radius.

DRIVING BELT—Endless B-section V-Belt, industrial grade.

PRESSURE SHEAVES—2 1/2 in. dia. with 3/8 in. bore.

IDLER SHEAVE—4 in. dia. x 5/8 in. bore V type or 5 1/2 in. dia. x 5/8 in. bore flat type.

TAKE-UP—Take-ups provided to maintain proper V-belt tension. Includes 4 3/8 in. dia. x 5/8 in. V type take-up sheave.

BEARINGS—Tread rollers have pre-lubricated ball bearings. Flange and pillow block bearings are sealed, pre-lubricated with eccentric lock collar.

MOUNTING BRACKET—Bracket is supplied to attach spur to side channels of 190-ACC, 190-ACZ, or 190-LR conveyors.

BUTT COUPLINGS—Standard for connecting 190-ACC, 190-LRC, 190-ACZ, or 190-LR conveyors.

SPEED REDUCTION—Sealed worm gear reducer driven by V-belt. No. 50 roller chain to drive sheave.

MOTOR—1/2 HP—208/230/460/575V—3 PH. 60 Hz. Totally Enclosed.

CONVEYING SPEED—Constant 65 FPM.

CAPACITY—500 lbs. total distributed live load.

FLOOR SUPPORTS—Now supplied as optional equipment.

• SPUR APPLICATIONS

Live Roller Spurs are used to transfer cartons, etc., onto and off of main conveyor lines. The illustrations below show the correct usage of Plows and Turning Wheels with Spurs in Diverging and Converging applications.

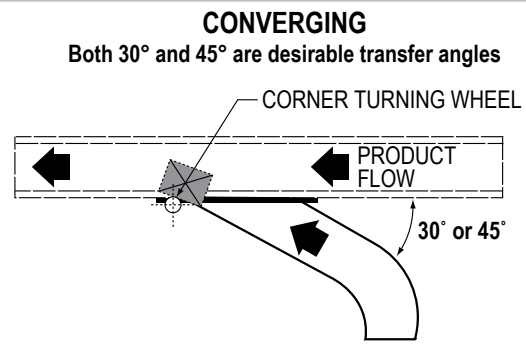
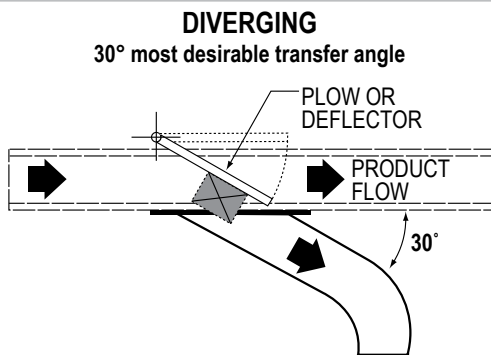

MOUNTING BRACKET

The 190-LRS is equipped with mounting brackets to attach unit to side channel of 190-ACC, 190-ACZ, or 190-LR.

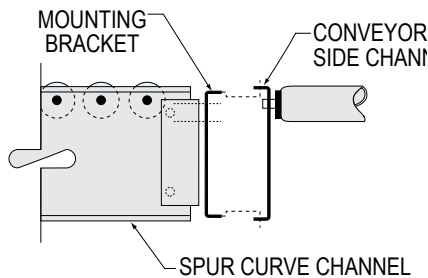

SPUR FLOW (Specify)

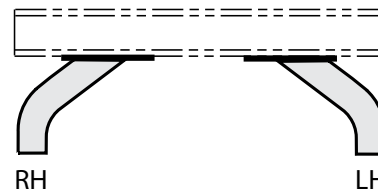

• OPTIONAL EQUIPMENT

FLOOR SUPPORTS—MS Type floor supports are available with a wide range of adjustment. Specify top of belt or roller elevation. One support required at every bed joint and ends of conveyor. Holes in feet for lagging to floor. Knee braces recommended above MS-6 support.

CONVEYING SPEED—Other constant and variable speeds from 25 to 120 FPM. **NOTE:** Capacity affected with speed change.

END DRIVE—Mounted on inside radius. Minimum elevation 18 7/8".

SIDE MOUNTED DRIVE—Motor reducer unit mounted to side of conveyor. Minimum elevation—11 1/4 in.

O-RING DRIVE CHAIN—With sealed in lubricant (Recommended for applications that do not permit regular lubrication).

GUARD RAILS—Adjustable Universal Channel Guard Rail, fixed channel, type A & B angle. (See Accessory section.) **NOTE:** If product comes in contact with guard rails, product flow will be affected.

POLY-TIER SUPPORTS—36 in. to 120 in. support heights in 6 in. increments. Knee braces supplied.

CEILING HANGERS—5/8 in. dia. x 8 ft. long unplated rods fully threaded. Other lengths and galvanized rods available.

SLAVE DRIVEN—Standard drive may be omitted and curve slave driven from 190-ACC, 190-ACZ, or 190-LR conveyors. (Specify by sketch, location of slave connection). Minimum elevation 11 in.

MOTORS—Energy efficient, single phase, brakemotor, other characteristics. 1 HP maximum.

ELECTRICAL CONTROLS—Non-reversing or reversible magnetic starters and push-button stations. AC variable frequency drive.